

ARON

ADVANCED

We offer quality





INTRODUCTION :

Arcon Advanced Trading Co. for building materials. was established as member of Arcon builders development group to serve our clients is our first priority. we are not just providing products, but we offer a full package of high quality, time commitment and unique solutions.

OUR MISSION :

Is to become a world class manufacture & supplier of high quality building products to the local & international markets.

OUR VISION :

Is based on having a strong, ambitious & innovative work force who strongly believes in facing challenges with great spirit.



Arcon Advanced management team has set the following principles & philosophy

- ◆ Shall approach business from a global perspective.
- ◆ Shall & will attend to the desires, needs & requirements of its clients.
- ◆ Arcon Advanced is going to be open to now ideas & proposals from it own employees & its clients.
- ◆ Shall & well respond to any customer needs & requirements with speed & agility.
- ◆ belives in the individual values & will towrds achieving synergy between its own people, clients & suppliers.

Arcon Advanced **PHILOSOPHY**

- ◆ **DUTY** : will deliver its utmost efforts to ensure customer satisfaction.
- ◆ **RESOLVE** : management will create a vigorous & open-minded culture through diligent self discipline & ethical behavior.
- ◆ **FOUNDATION** : shall & will learn from the market, whether locally or inernationally, respond to client's needs, requirements & surpass its clients expectations.

Approach : team shall & will devote itself to innovation, creation & the realization of its goals & dreams.

Objective: will strive to be world class manufacturer & supplier of building products to the local & international markets, but through constant technical improvement, research developments & innovation.



Arcon Advanced Services

1. Manufacturing of Products, Factory for steel products was established in 2006 and has been expanding ever since through the production of a variety of products ranging from.
 - A. Cable management systems :
Cable Trays, Cable Ladders, Cable Trunking and channel support systems
 - B. Cladding Fixation
 - C. Steel lintels and block work accessories
 - D. Plasterers beads and expanded metal
 - E. gypsum profiles
 - F. Garbage and linen chutes

2. Trading division is responsible for trading activities to supply building & construction materials to major & minor projects to the retailer outlets. This division of Formation is supplying wide range of products & it has distribution agencies for international company. Trading division is ready to supply most to the requirements & different products to all kind of construction projects.



For Aluminum & Glass System, Glossy, Metal ,Decorative Works Of Art And Interior Partitions

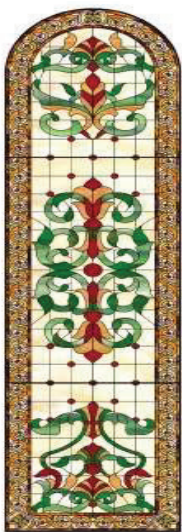

PRN-015

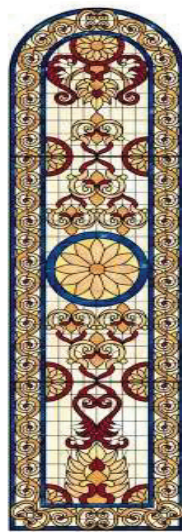

PRN-016

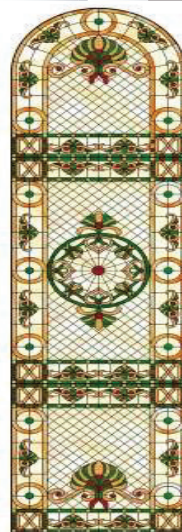

PRN-017

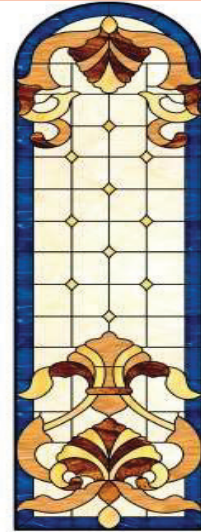

PRN-018

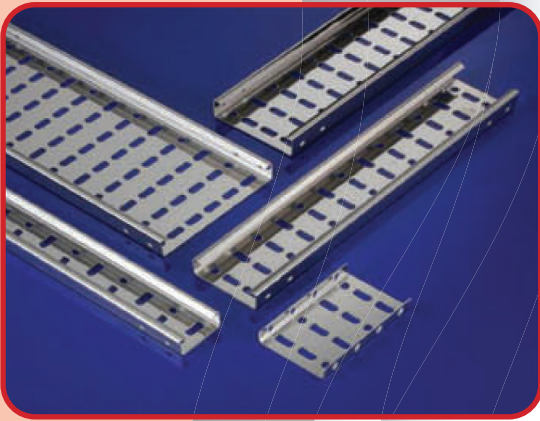

1. CABLE TRAYS

Cable Trays are designed to meet most requirements of cable and electrical wire installations, and comply to local and international standards of fabrications and finishes.



2. CABLE LADDERS

Cable Ladders of different side heights are available upon request, ex: 50mm, 15mm, 100mm and others.

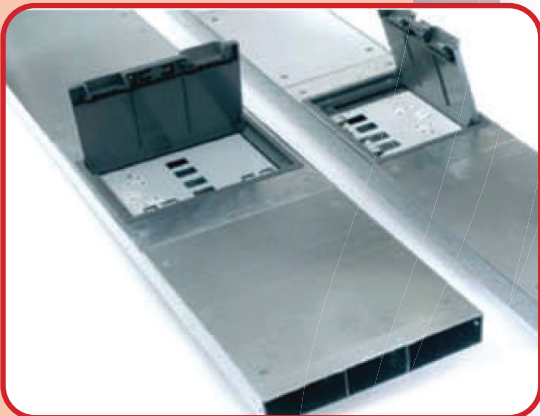

3. CABLE TRUNKINGS

Cable Trunkings and Accessories are offered in a comprehensive range. Mill galvanized, hot-dip galvanized, and powder coated are the various finishes produced in our factories.



4. STRUT CHANNELS

Channels Systems provides an economical solution for electrical, Mechanical and industrial supports with a wide variety of applications in the construction industry. Applications:- Pipe and Conduit Supports - Tunnel Pipe Stanchions Racks and Shelvings -all Framings.

5. LINTELS & BLOCK WORK ACCESSORIES

Steel Lintels provide a combination of strength and light weight, resulting in efficient load bearing performance and increased productivity on site. They are characterized by their ease of installation in addition to time as well as money saving.

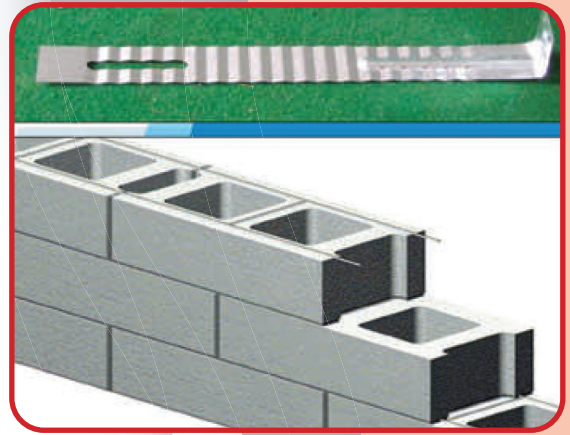

6. PLASTERING ACCESSORIES

Expanded Materials help the formation of joints, protection of corners and resistance against cracks, chips and impact damage.

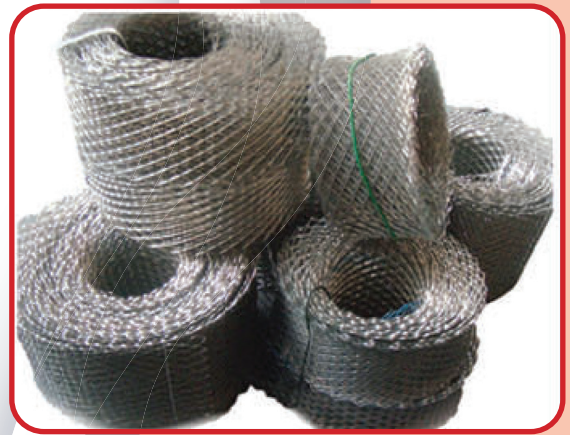

7. MARBLE & GRANITE FIXING

Cladding Fixation includes design, calculation and production of several types of mechanical fixing and accessories used for cladding purposes. Stainless and galvanized steel are among the various materials used in the fabrication.



8. GYPSUM PROFILES

Arcon provides a complete product range for dry wall and ceiling constructions. Studs, Runners, Furring Channels, Ceiling Channels and Wall Angles are among the range of products produced to service the dry wall installers.

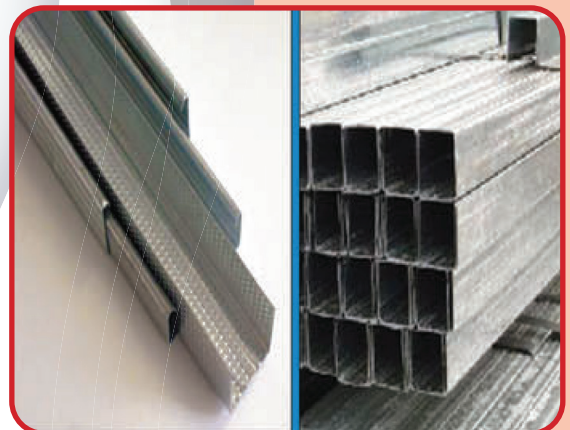



9. GARBAGE CHUTES

Garbage chutes are common in high rise apartment building and are used to collect the building's garbage in the on place. often the bottom and of the chute is placed directly above a large waste stair wells.

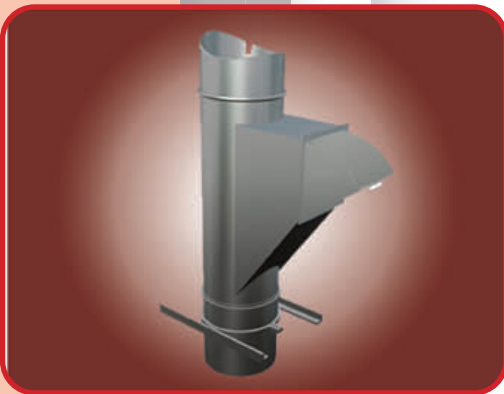

10. LINEN CHUTES

Linen Chutes can be instaired in Hospitals, Hotels, Residential the advantage of Linen Chutes, The facilitates total building Linen collection at one single point, Linen disposal with ease and safety, Reduces man power.



11. PIPE CLAMPS & HANGERS

Pipe Clamps and hangers used in the support of pipes and equipments are manufactured according to the highest standards of fabrication. A diversified choice of:

- * Pipe Hangers - Pipe Clamps - EMT Straps - Omega Clamps Beam Clamps
 - * J and U-Bolts and Threaded Accessories
-



12. PVC WATERSTOPS

Arcon Waterstop (A High Grade Flexible Polyvinyl Chloride Waterstop) is designed for use in any concrete structure which contains joints and is subjected to a hydrostatic load on one face of the structure. It prevents water movment through concrete joints in water reservoirs, canals, dams, sewage treatment plants, bridges, stadiums, basments, floor salbs, parking garages, and similar structures.

13. FORM WORK ACCESSORIES

Form work accessories include tie rods, thru sleeves base plates, wing nuts, anchor nuts, thru cones water barriers, chamfers, and others.



14. PVC Spacers, Chamfers, Pipes & Canes

Spacers, also known as cover blocks, provide the specified concrete cover to the reinforcement used in construction both before and during concreting. PVC chamfer strips create durable out side corners on concrete columns beams or walls.



15. SCAFFOLDS, FORMWORK, CONSTRUCTION EQUIPMENTS

Arcon provides a complete formwork and scaffolding solutions. Its products and solutions meet the requirements of the most complicated applications. Its range includes: Horizontal and vertical formwork, scaffolding, props and others.

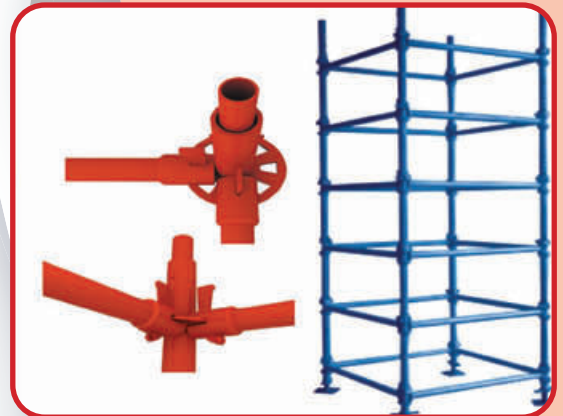

16. Expanded Polystyrene & Block Hardy





17. FILLER BOARD

Arcon is manufactured from highly resilient softwood fibers coated with bitumen. It is dry and clean, and cannot extrude any form of staining matter. It is resistant to moisture penetration and ice formation in the joint. It is immune to dry and wet rot, fungus and most forms of insect attack or similar forms of deterioration. It completely fills joints under repeated cycles of expansion and contraction with minimum extrusion.



18. CORK BOARD

CORKJOINT consists of extremely selected cork granules securely bonded together by a synthetic resin of an insoluble nature and molded under heat and pressure. CORKJOINT is strong, light in weight, flexible and acid resistant. CORKJOINT is essentially recommended for joints in concrete, brick or blockwork, require sealing and filing. CORKJOINT is a natural incorruptible and highly resilient product, suitable for filling expansion joints where expansion and contraction of joints is very intense.



19. POLYETHYLENE ROLLS

A blown polyethylene film resistant to alkalis, salts, acids and chemicals found in sub-soils; fully stable and waterproof it is an anti-corrosive and weather resistant blown polyethylene film.



20. NONE WOVEN GEOTEXTILES

A natural choice in designing, building and constructing works including roads and highways; ground drainage and filtration systems; hydraulic works, waste disposal sites and water purifying plants.

21. EXTRUDED POLYSTYRENE THERMAL INSULATING BOARDS

Extruded Polystyrene rigid thermal insulation boards mainly used for insulating roofs, walls, and floors severe climate conditions. Insulation boards, manufactured accounting to ASTM C578, also help the prevention of ultra violet rays from penetrating roofs, walls and floors.

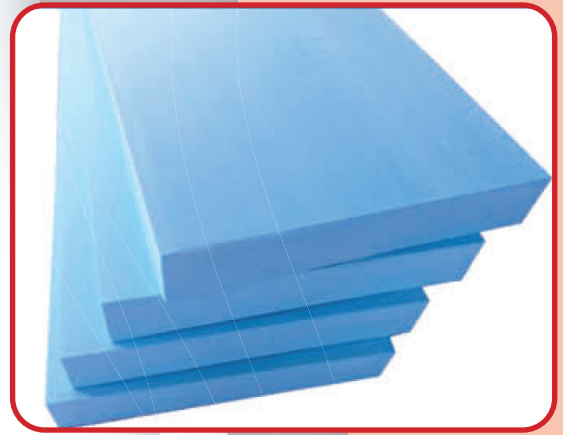

22. WATER PROOFING MEMBRANES PROTECTION BOARDS PRODUCTS

Includes hot applied bituminous membranes, Liquid membranes, protection board, fiber glass scrim mesh, aluminium flashing.

izomaks



23. CUNSTRUCTION CHEMICAL PRODUCTS



24. GLUE FOR MARBLE & GRANITE

Glue for Marble & Granite (2-components polyester) is a synthetic resin-based adhesive with a specific weight between 1.5 and 1.65 gram /cm³.



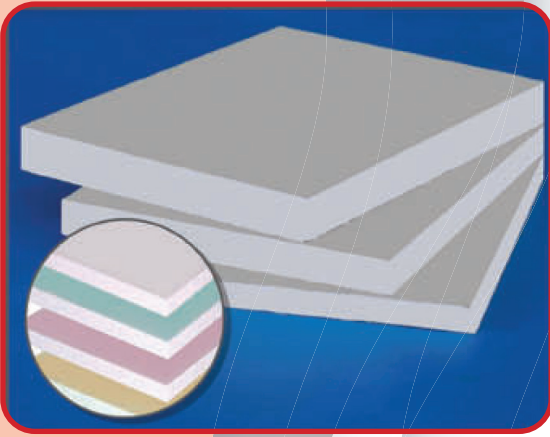

25. GYPSUM & FIBER CEMENT BOARD

Gypsum board are designed for wall and ceiling applications to meet most general construction needs. Fiber Cement Board is a new type of decorative board owns high marketing demand. The product enjoys the features of high strength in the aspects of fireproofing, moisture proofing and easy processing. Meanwhile, it has the performance of comprehensive environment protection, asbestos free, no formaldehyde, and no blastmogen. It does no harm to human body.



26. ONE-PART POLYURETHANE SEALANT

Two parts polyurethane sealant & two parts polyurethane sealant (self leveling)



27. BACKING RODS

Arcon Backing Rods is an extruded closed cell polyethylene foam which is both flexible and compressible. Backing Rods are designed as pre-molded joint fillers for expansion joints in civil engineering and building construction works of all types. They are acrylics, butyl rubbers, polyurethanes, general-purpose mastics, bitumen based sealants and putties.

29. FIXATION SYSTEMS

Fixation Systems are made up of different types ranging from wall plugs, frame fixations, nylon hammer fixations, nylon plugs with hooks and eye screws, steel expanding anchors, stainless steel anchors, and through-anchors and drop-in anchors to suit all users' needs.



30. GRINDING / CUTTING BLACK DISCS

Arcon product line cutting discs for universal use and various material cross sections made of metal or steel and stone. Suitable for sheet metals, profiles and general applications as well as stone.



31. DIAMOND CUTTING BLADES

Diamond cutting blades durable, different applications' cutters used for granite, marble, natural stone and concrete products.

32. Electrical Power Tools, Accessories & More

Electrical Power Tools comprise the following range: Hammers, drills, percussion drills and diamond drills, screwdrivers and battery tools, wall chasers, angle grinders and straight grinders, jig saws and circular saws, and many more to address the most diverse applications in wood, metal, concrete and block. also has its own range of innovative, high-quality accessories designed to perfectly compliment power tools.



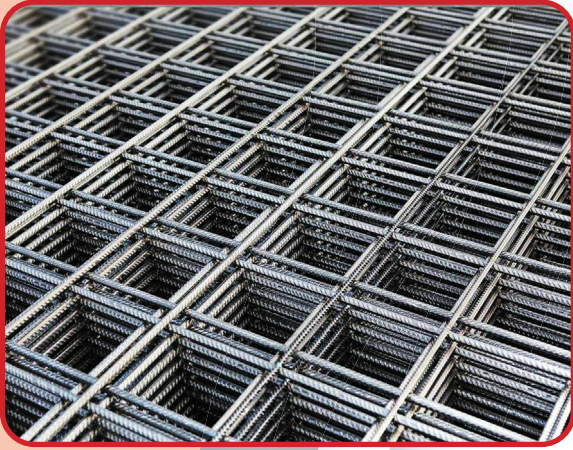

**Deformed Welded
Wire Mesh**



**Epoxy Coating
Division Rebars
& Wiremesh**



**Gabions - Mattresses
& Netting**



**Chainlink and
Weldmesh
Fencing Products**

Galvanizing Plant



Gantry & Cantilever



Traffic Signs



Road Marking Paints



Measuring Tools and Levels



Lead Sheets (Radiation Protection)



KITCHEN Equipments



Raised Access Flooring "Supply & Apply"



Expansion Joints Covers "Supply & Apply"



Handrails & Corner Guards "Supply & Apply"



Speed Bumps & Bumper Guards "Supply & Apply"



PVC Vinyl For Hospitals "Supply & Apply"



Ceiling Systems

(Mineral, Fiber, Metal, Gypsum "Supply & Apply")



Toilet partition "Supply & Apply"



Wooden Doors & Windows "Supply & Apply"



Tiles" Fixing Products



Tiles" Grouting Products



Color Renders & Decorative Finishes

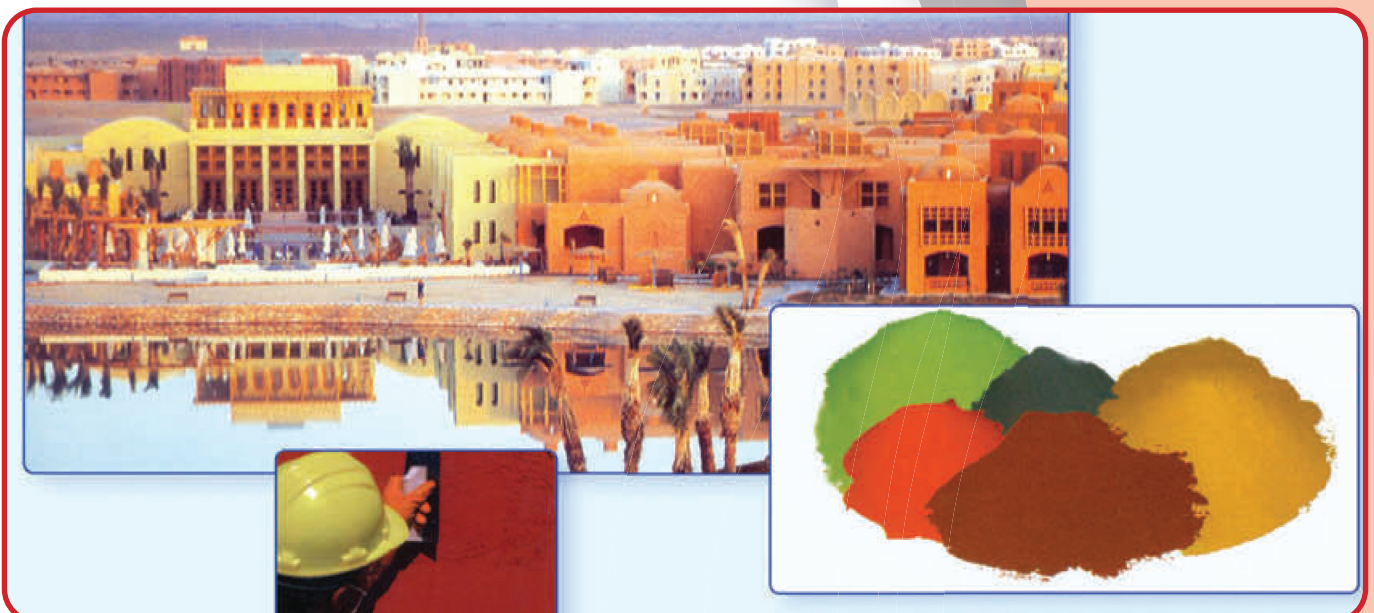

Wall & Celings Plasterin Products



Putties & Skin Coat and Crack Filler



Flooring Products



Wood, Building Wire, Concrete Nails & Construction Tools

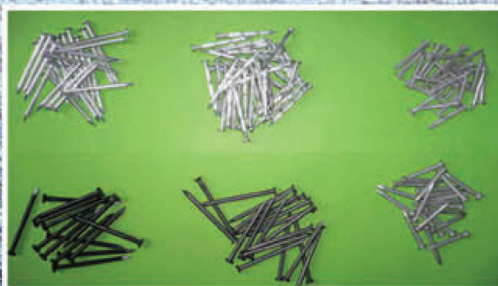
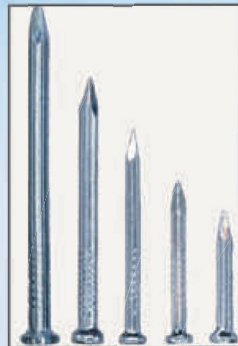

Cables & Wires



- MV CABLES
- LV CABLES
- NYA WIRES
- THHN WIRES
- FLAT & FLEXIBLE WIRES
- CONTROL CABLES
- FIBER OPTIC
- INSTRUMENTATION
- SPECIALITY CABLES

ELSEWEDY ELECTRIC



Saudi Cable

Lighting & Fixtures



- STEEL POLES
- FIBER POLES (GRP)
- LAMPS
- LIGHTING FIXTURES
- FLOOD LIGHTS
- LIGHTING COMPONENTS
- FUSE BOXES
- LIGHTING GEAR



Conchiglia

Cable Management



- CABLE TRAYS
- STEEL CONDUITS & FITTINGS
- PVC CONDUITS & BOXES
- STEEL BOXES
- FLEXIBLE CONDUITS & FITTINGS



DECODUCT

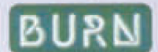

Wiring Devices



- WHITE PLASTIC RANGE
- DECORATIVE RANGE
- WIDE ROCKER RANGE
- METALLIC RANGE



Cable Accessories



- CABLE LUGS
- CABLE TOOLS
- CABLE GLANDS
- WARNING & ELECTRIC TAPES
- CABLE JOINTS
- TERMINATION KITS
- DRUM JACK & CABLE ROLLERS

Nissad

REMA

CTL COMPONENTS

Plymouth

BVI

CMP

3M Worldwide

Other Materials



- EARTHING MATERIALS
- LIGHTNING SYSTEMS
- CHANGE-OVER SWITCHES
- DISCONNECT SWITCHES

GE General Electric Company

EFEN

thermOweld

furse

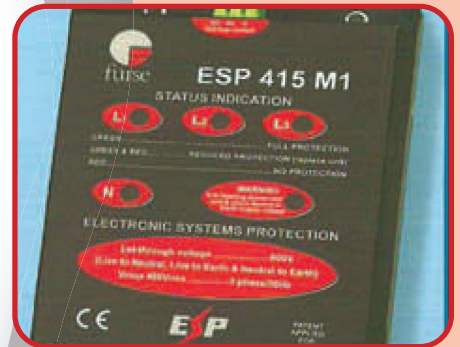



Panel Board Factory :

The Basic Product Range Includes:

- Electric distribution panel boards & Control panels
- Automatic transfer switches & Power factor correction
- Compact enclosures
- Junction boxes
- Cable trays

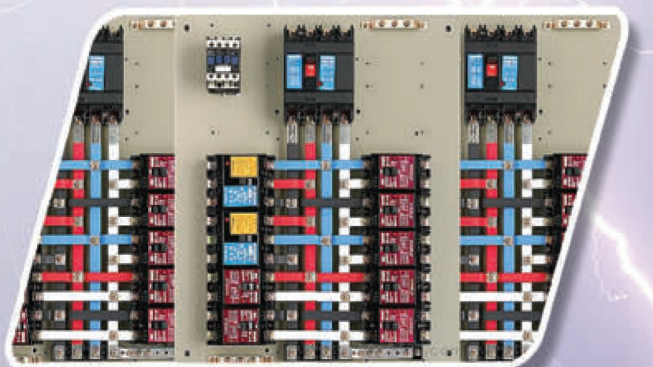
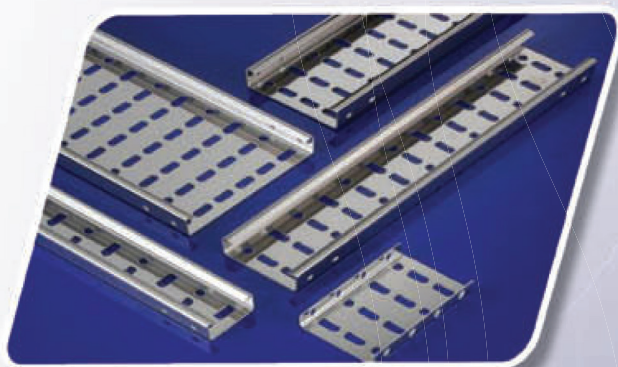



ARON

ADVANCED



KINGDOM OF SAUDI ARABIA
Jeddah - Riyadh - Khamis Mushait - Sakaka